



Product Data Sheet

Pre-Mount and Mount Press

Model SMP-200

smtgroup.com
(518) 462-5431



The **Simmons SMP-200 Pre-Mount and Mount Press** is a fully automatic production wheel press for mounting railcar wheels to axles. The SMP-200 takes pre-machined wheels and axles and accurately positions and mounts the wheel set in a fast, efficient, and AAR-compliant manner.

The machine cell combines wheel bore and axle lubrication stations, pre-mount press, and mount press. Wheels are loaded into wheel carts that transport them to the wheel bore lubrication station. Once lubricated, the cart loads the wheels into the pre-mount press. Axles are loaded directly into the axle lubrication station, or held in an optional axle rack. After lubrication, the axle is transferred to the wheel set cart that holds the axle during the pre-mounting and mounting operations. The pre-mount system pre-assembles the wheel set, pressing the wheels onto the axle with 19 tons of force. Pre-mounting is fully automatic and eliminates pre-assembly of the components in the mounting press, saving production time. After the wheels are pre-mounted to the axle, the wheel set cart transfers the wheel set to the intermediate elevator, which transfers the pre-mounted wheel set from the first position on the wheel set cart to the second position. The pre-mounted wheel set is then transferred into the mounting press.

The 200-ton mounting press performs the final assembly of the railway wheel set. Matched wheel and axle assemblies are indexed into the mounting press from the pre-mount station. The press includes special tooling and an automatic gauging system. The gauge system automatically positions the wheels on the axle centerline and at proper track gauge, produces wheel sets that are consistent and free of operator error. The automatic press includes a Wheel Press Recorder, which produces a pressure diagram, reflecting tonnage over distance. The tonnage recorder also stores the pertinent wheel and axle data such as wheel and axle serial numbers, mount number, and misfits, allowing the stored data to be and transferred to a central computer.



Product Data Sheet

Pre-Mount and Mount Press

Model SMP-200

smtgroup.com
(518) 462-5431

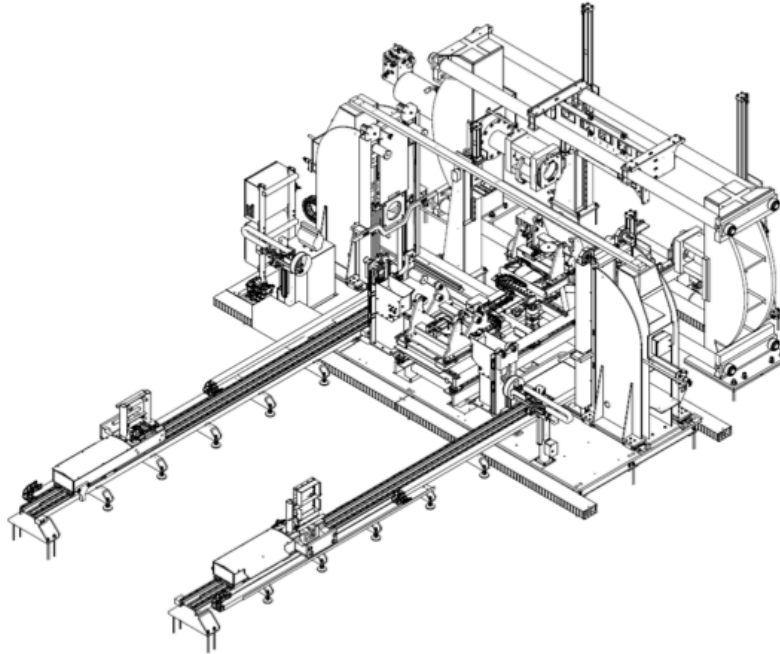

Machine Dimensions

Overall Machine Length (not including wheel carts)	175.5 in.	4455 mm
Overall Width	267.5 in.	6797 mm
Maximum Height	113 in.	2871 mm
Total Machine Weight	47700 lbs.	21637 kg

General Specifications

Takt Time	2 minutes 10 seconds	
Wheel Centering Accuracy	+/- 0.020 in.	+/- 0.51 mm
Back-To-Back Repeatability	+/- 0.015 in.	+/- 0.38 mm
Max. Pressing Force - Mount Press	200 short tons	181 metric tons
Max. Pressing Force - Pre-Mount Press	19 short tons	17.2 metric tons
Press Ram Stroke - Mount Press	36 in.	914 mm
Ram Extend Speed	250 in/min	6350 mm/min
Maximum Pressing Speed - Mount Press	11.3 in/min	287 mm/min

Utility Requirements

Electrical Power	60 kW	
Hydraulic Reservoir	200 US gallons	757 liters

Wheel Set Dimensions

Maximum Wheel Diameter	44 in.	1120 mm
Minimum Wheel Diameter	28 in.	711 mm
Maximum Axle Length	102 in.	2590 mm

Updated August 28, 2020